

www.torkongroup.com



**ENTFESSELN SIE DIE
LEISTUNG.**

**ATTACHMENTS
PRODUKTKATALOG**



TORKON[®]

Attachments

ÜBER UNS

www.torkongroup.com

TORKON
Attachments



UNSERE VISION UND MISSION

Unser Ziel ist es, durch ein Höchstmaß an Qualität und Technologie die Standards in diesem Sektor zu setzen.

Als Torkon Attachments ist es unsere Vision, weltweit führend in der Industrienbaugerätebranche zu sein und die Branche mit innovativen, langlebigen Produkten anzuführen. Indem wir die technologischen Entwicklungen in der Branche genau verfolgen, wollen wir unsere Produkte kontinuierlich verbessern und die am besten geeigneten Lösungen für die Bedürfnisse der Benutzer anbieten.

Torkon Attachments stellt hochwertige, robuste und zuverlässige Anbaugeräte her, die in der Branche Pionierarbeit leisten und innovativ sind. Wir bieten eine breite Palette von Produkten für den Einsatz in der Landwirtschaft, im Baugewerbe, im Bergbau und anderen Bereichen.

Unser Fokus auf das Verstehen der Kundenbedürfnisse und das Erfüllen dieser Bedürfnisse auf die effektivste Weise hat Torkon Attachments zu einer bevorzugten Marke in der Branche gemacht. Jedes unserer Produkte ist mit Langlebigkeit, Leistung und benutzerfreundlichen Merkmalen ausgestattet, so dass unsere Kunden auch unter den härtesten Bedingungen maximale Produktivität erzielen können.

Wir, Torkon Attachments, legen großen Wert auf Innovation und nutzen Technologie auf höchstem Niveau in unseren Produktentwicklungsprozessen. Mit unseren modernen Produktionsanlagen und unserem erfahrenen Ingenieurteam heben wir die Standards der Branche kontinuierlich an.

Die Zufriedenheit unserer Kunden hat für uns immer Priorität. Als Team von Torkon Attachments stehen wir unseren Kunden auch weiterhin mit unseren Dienstleistungen vor und nach dem Kauf zur Seite. Ganz gleich, ob Sie eines unserer Standardprodukte bevorzugen oder ob wir mit unseren Speziallösungen eine Sonderanfertigung für Sie machen, wir garantieren Ihnen in jedem Fall den besten Service.

GABELSTAPLER

GABELSTAPLER

www.torkongroup.com

SEITE **06-17**

TORKON[®]

Attachments

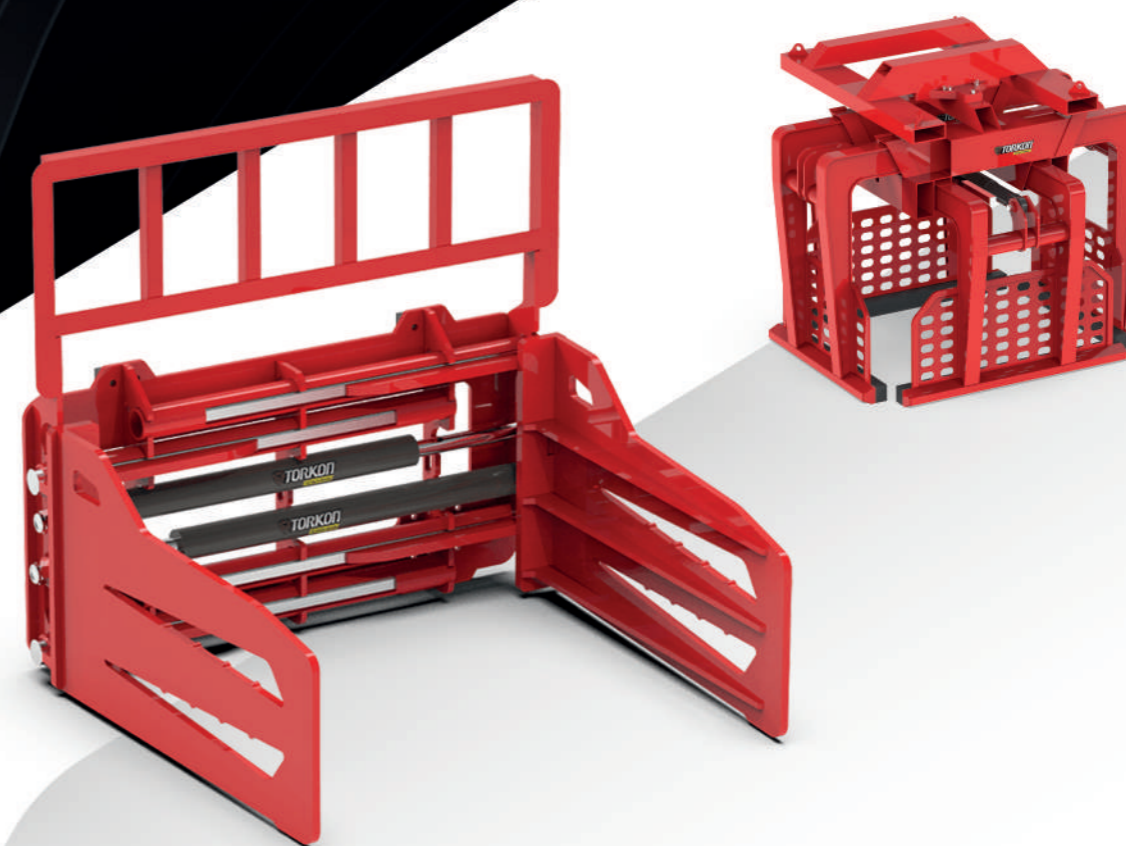



BALLENKLAMMER



6



PRODUKTINFORMATION

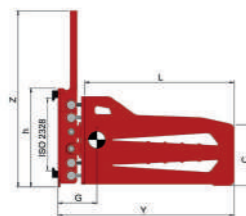
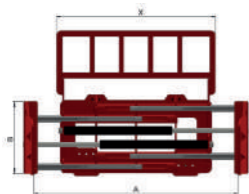

	MODELLNUMMER	CBC
A	ÖFFNUNGSBEREICH	545-2125 MM
G	EIGENSCHWERPUNKT	273 MM
H	KÖRPERHÖHE	700 MM
B/C/L	ARMABMESSUNG	620/430/1050 MM
X/Y/Z	GESAMTMAßE B/L/H	1360/1240/1245 MM
M	EIGENGEWICHT (KG)	490 KG
MA	TRAGFÄHIGKEIT (KG)	2300 KG
ISO 2328	ISO - NORM	3A

STAPLERSCHAUFEL

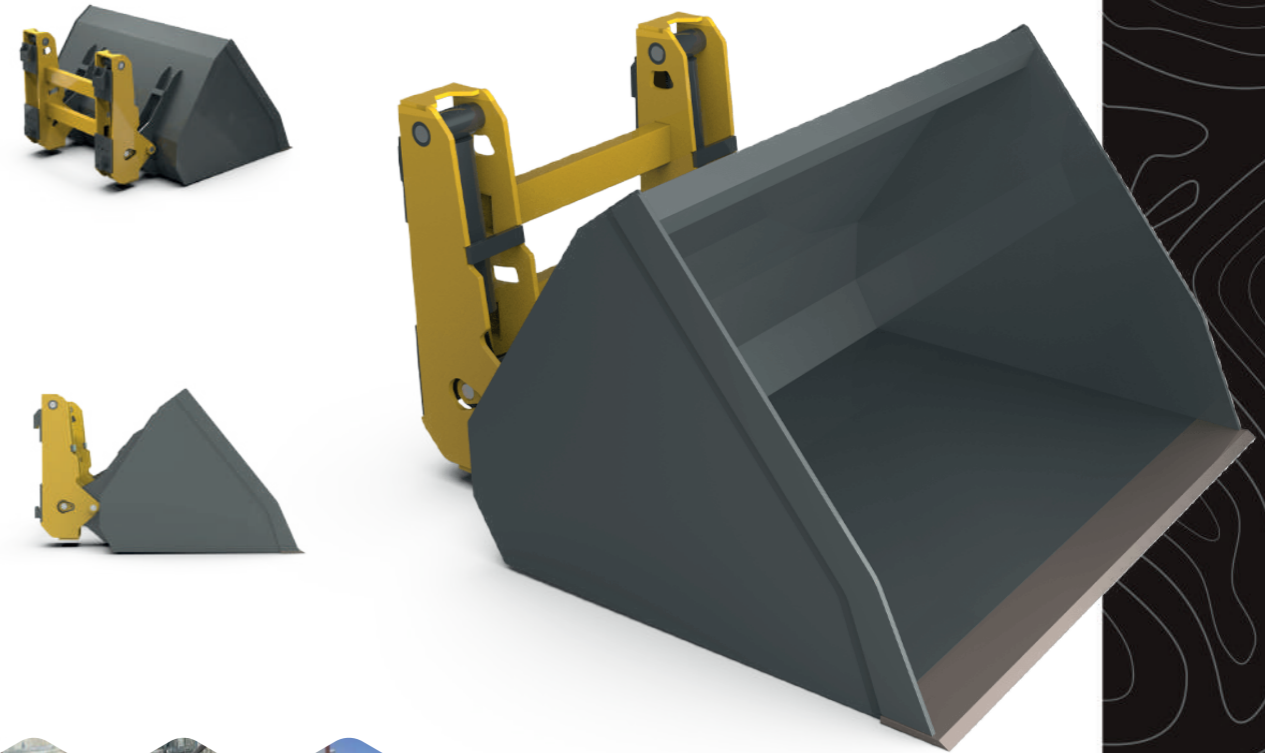

7



PRODUKTINFORMATION

	MODELLNUMMER	CFB-80	CFB-100
V	INHALT	0,80M ³	1M ³
X/Y/Z	GESAMTMAßE L/B/H	1465/1505/905 MM	1561/1505/945 MM
L	LÄNGE	1500 MM	1500 MM
A1	BELADEWINKEL	46,2°	46,2°
A2	ENTLADEWINKEL	42,2°	42,2°
G	EIGENSCHWERPUNKT	515 MM	560 MM
M	EIGENGEWICHT (KG)	440 KG	470 KG
MA	TRAGFÄHIGKEIT (KG)	1500 KG	2000 KG
ISO 2328	ISO - NORM	3A	3A

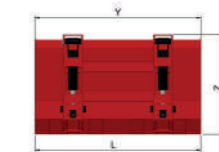
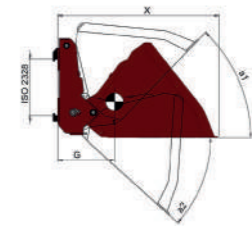



ZINKENVERSTELLGERÄT



8

PRODUKTINFORMATION

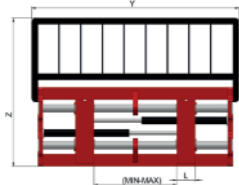

	MODELLNUMMER	FPA
ISO 2328	ISO-NORM	3A
D (MIN - MAX)	ÖFFNUNGSBEREICH GABEL	60 / 1180 MM
X/Y/Z	GESAMTMAßE B/L/H	165/1680/1200 MM
L	ARMTRÄGER	150 MM
G	EIGENSCHWERPUNKT	67 MM
M	EIGENGEWICHT	350 KG
MA	TRAGFÄHIGKEIT	-

GABELSTAPLERSCHAUFEL

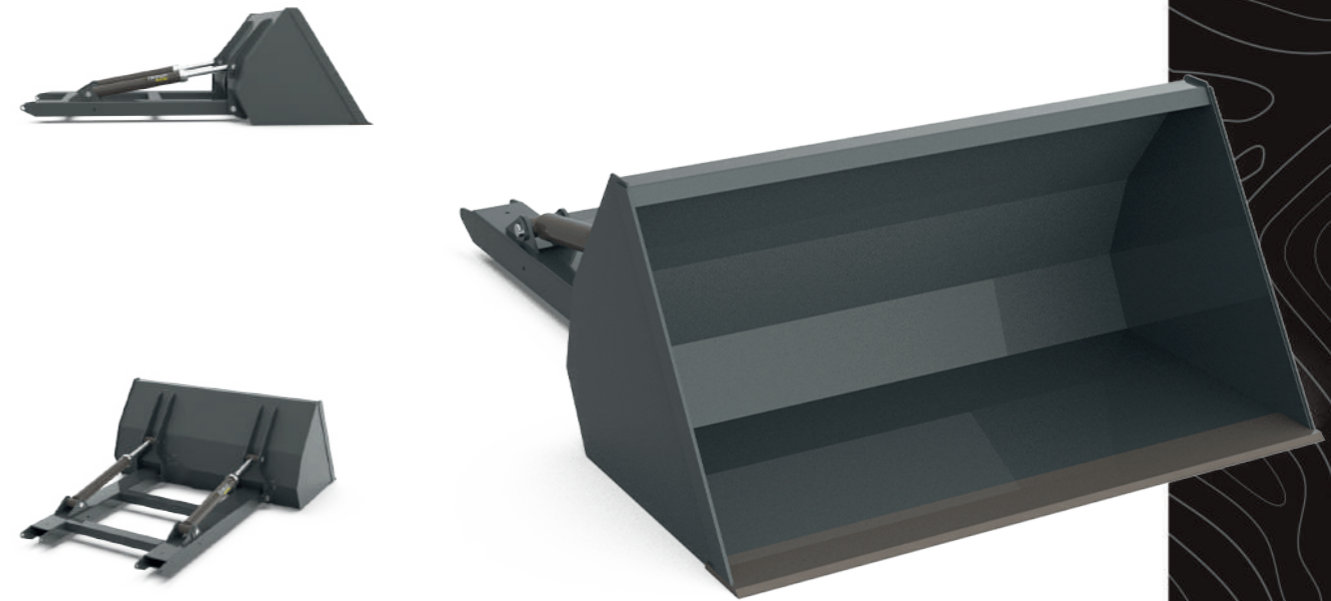

9

PRODUKTINFORMATION



	MODELLNUMMER	IFB-50	IFB-100
V	INHALT	0,5 M ³	1 M ³
X/Y/Z	GESAMTMAßE B/L/H	1500/2210/730 MM	1600/2560/950 MM
A1	BELADEWINKEL	53°	53°
A2	ENTLADEWINKEL	68°	68°
G	EIGENSCHWERPUNKT	1270 MM	1450 MM
M	EIGENGEWICHT (KG)	332 KG	425 KG
MA	TRAGFÄHIGKEIT	850 KG	1600 KG

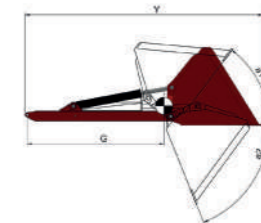



STEINKLAMMER MIT 2 ARMEN

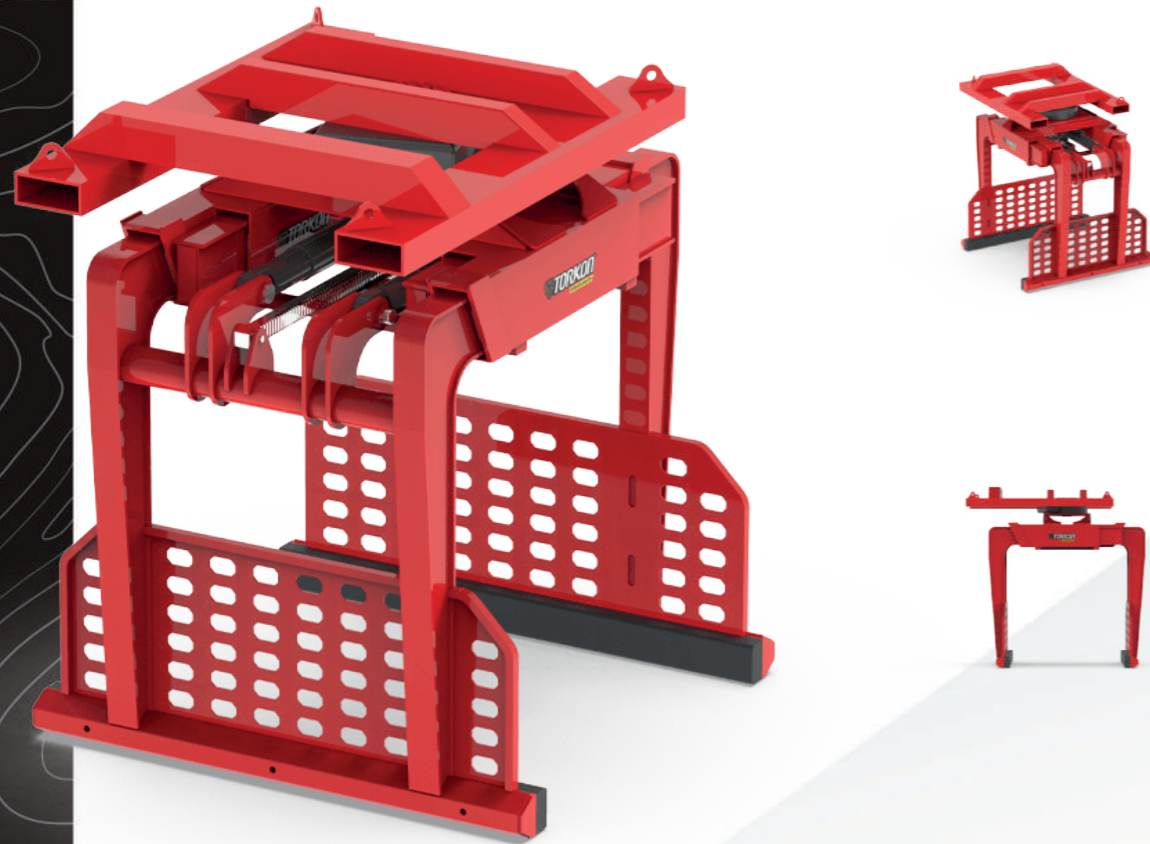

10



PRODUKTINFORMATION

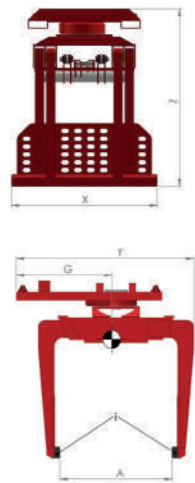

MODELLNUMMER	KSA-2	
X/Y/Z	GESAMTMAßE B/L/H	1300/1600/1600 MM
I	GUMMIAUFLAGEMAßE	50*80 / 50*100 MM
A	ÖFFNUNGSBEREICH	1000-1400 MM
G	EIGENSCHWERPUNKT	850 MM
M	EIGENGEWICHT	910 KG
MA	TRAGFÄHIGKEIT (KG)	2500 KG
A	DREHWINKEL DER ARME	360°

STEINKLAMMER MIT 4 ARMEN

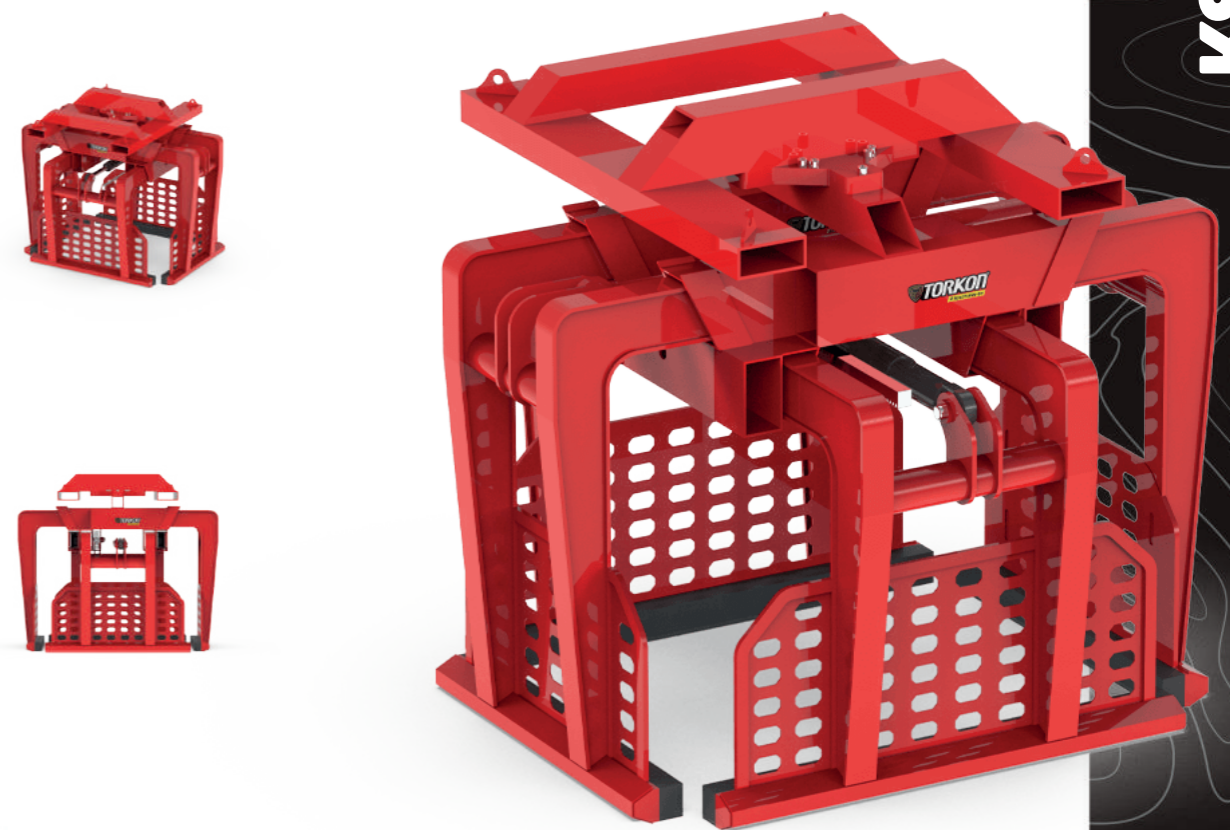

11



PRODUKTINFORMATION

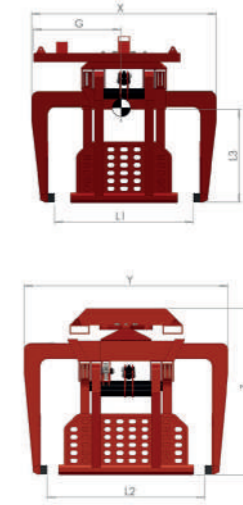

MODELLNUMMER	KSA-4	
X(MAX)	MAX. BREITE	1640 MM
Y(MAX)	MAX. LÄNGE	1810 MM
Z	HÖHE	1485 MM
L1 (MIN-MAX)	L1 (MIN.-MAX.)	800-1230 MM
L2 (MIN-MAX)	L2 (MIN.-MAX.)	950-1400 MM
L3	ARMHÖHE	830 MM
G	EIGENSCHWERPUNKT	780 MM
M	EIGENGEWICHT	1050 KG
MA	TRAGFÄHIGKEIT (KG)	2500 KG



ABSCHIEBER

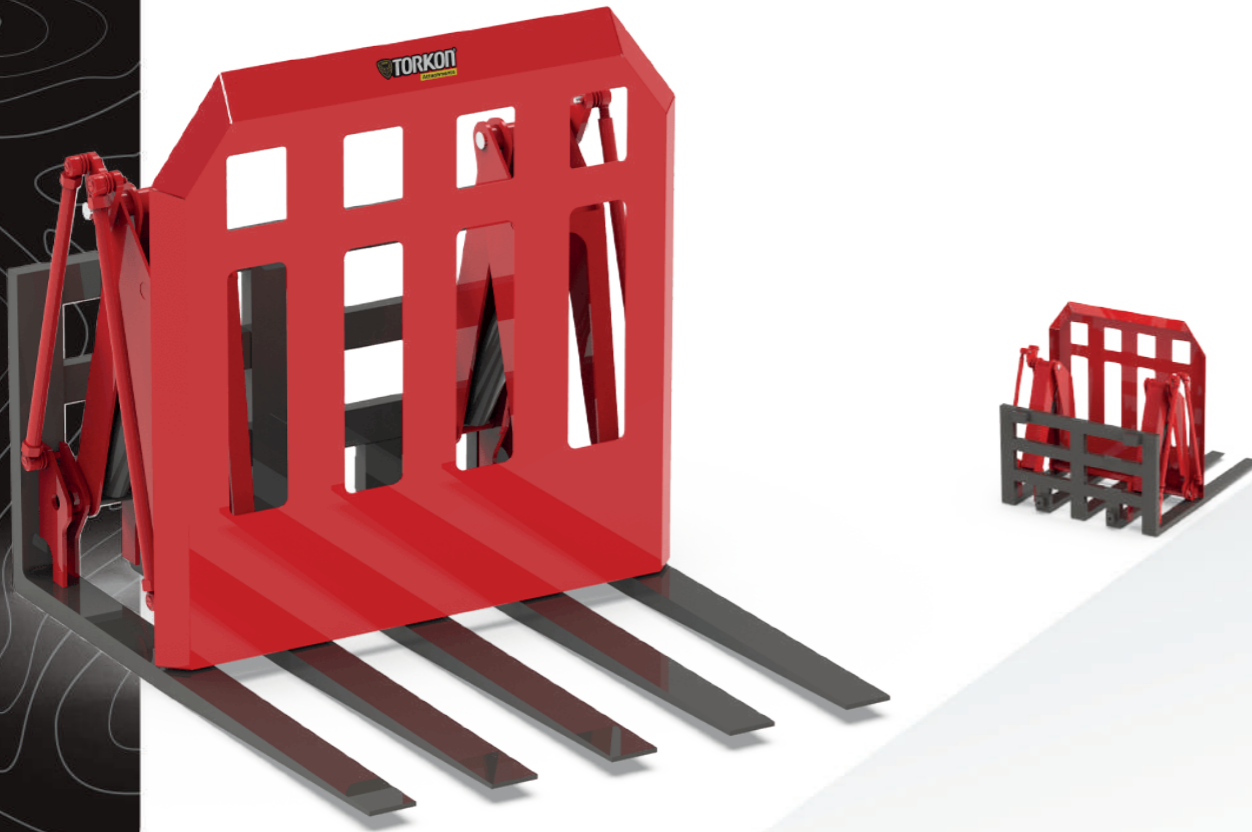

12

PRODUKTINFORMATION

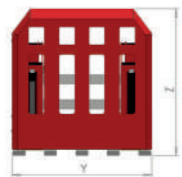
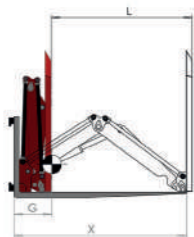

MODELLNUMMER	PPA
X BREITE	1450 MM
Y LÄNGE	1170 MM
Z HÖHE	1240 MM
L SCHIEBLÄNGE	1180 MM
G EIGENSCHWERPUNKT	320 MM
M EIGENGEWICHT (KG)	500 KG
MA TRAGFÄHIGKEIT (KG)	2500 KG

DREHGERÄT 90°



13

PRODUKTINFORMATION

MODELLNUMMER	RA9-VERT
L KÖRPERLÄNGE	1360 MM
X/Y/Z GESAMTMABE B/L/H	220/1540/635 MM
G EIGENSCHWERPUNKT	102 MM
K -	130 MM
ISO 2328 ISO-NORM	3A
A DREHWINKEL	103°
M EIGENGEWICHT (KG)	325 KG
MA TRAGFÄHIGKEIT (KG)	1500 KG

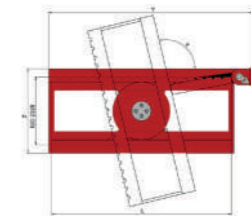



DREHGERÄT 90° VERTIKAL

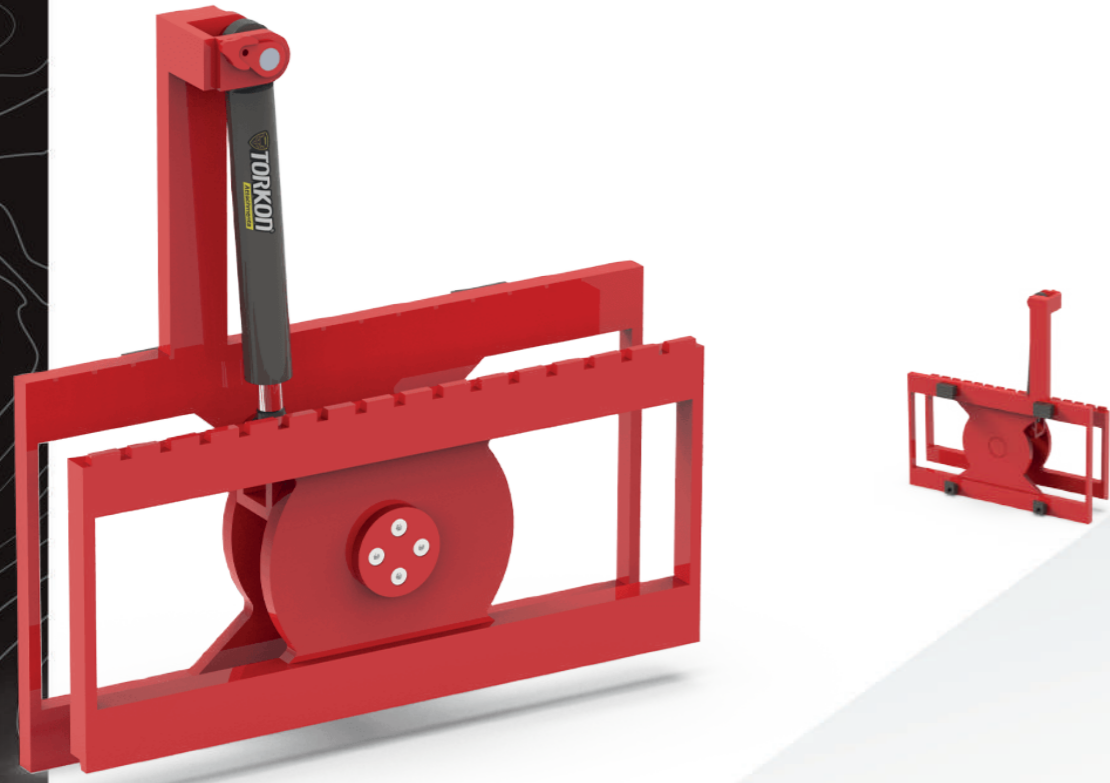

14

PRODUKTINFORMATION

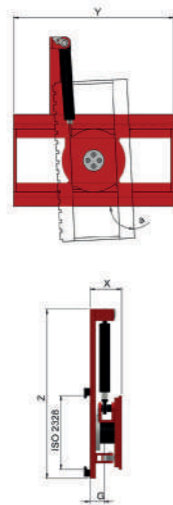

MODELLNUMMER	RA9-VERT	
X/Y/Z	GESAMTMAßE B/L/H	220/1100/1170
ISO 2328	ISO-NORM	3A
A	DREHWINKEL	93°
G	EIGENSCHWERPUNKT	98 MM
M	EIGENGEWICHT (KG)	310 KG
MA	TRAGFÄHIGKEIT (KG)	2000 KG

DREHGABELKLAMMER

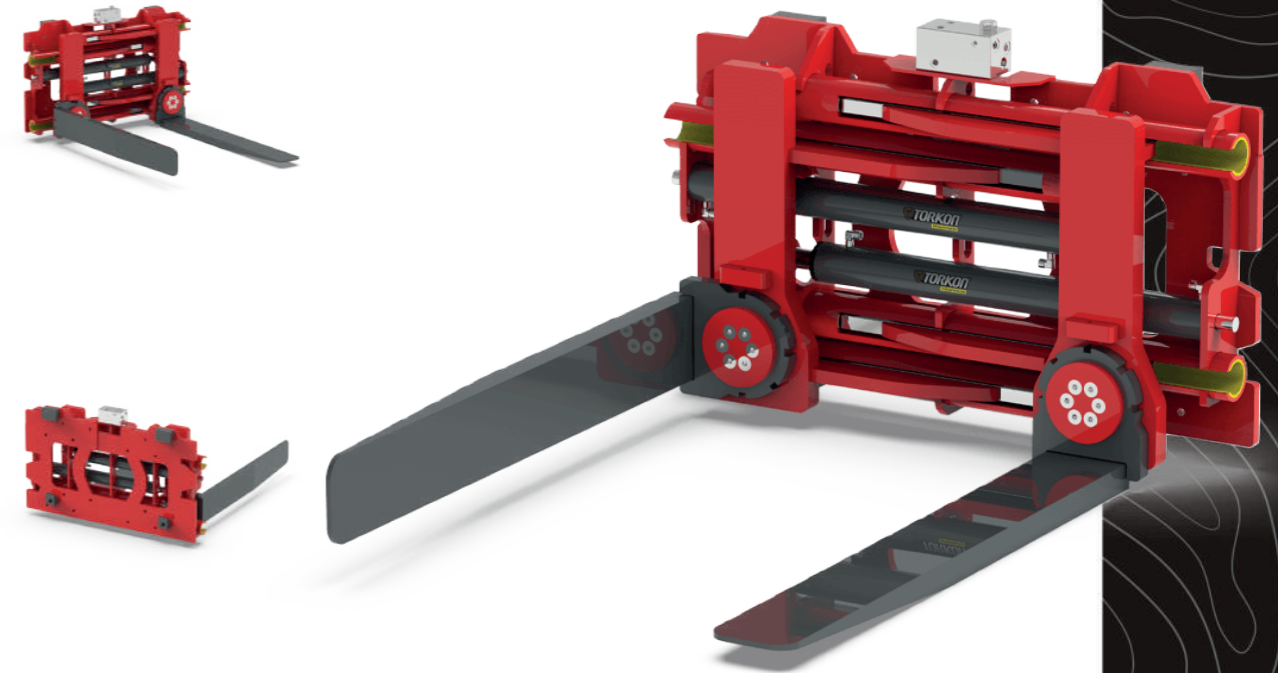

15

PRODUKTINFORMATION



MODELLNUMMER	RFBC	
A	ÖFFNUNGSBEREICH	490-1800 MM
X/Y/Z	GESAMTMAßE B/L/H	1425/1170/725 MM
H	KÖRPERHÖHE	680 MM
ISO 2328	ISO-NORM	3A
L	GABELLÄNGE	1200 MM
M	EIGENGEWICHT (KG)	480 KG
MA	TRAGFÄHIGKEIT (KG)	1500 KG

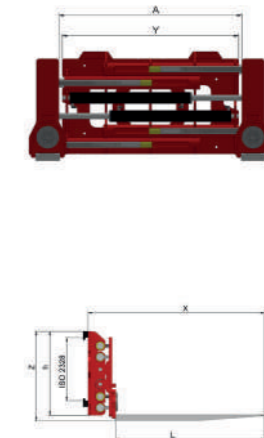



SCHAUMSTOFFKLAMMER



16



PRODUKTINFORMATION

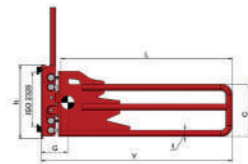
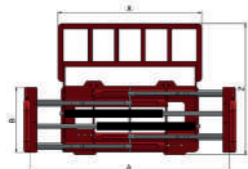

	MODELLNUMMER	SBC
A	ÖFFNUNGSBEREICH	620-2200 MM
G	EIGENSCHWERPUNKT	256 MM
H	KÖRPERHÖHE	700 MM
B-C-L-T	ARMMABE	620-498-1630-60 MM
X/Y/Z	GESAMTMAßE B/L/H	1360X1820X1245 MM
M	EIGENGEWICHT (KG)	440 KG
MA	TRAGKRAFT (KG)	1500 KG
ISO 2328	ISO NORM	3A

GABELSTAPLERKORB



17

PRODUKTINFORMATION

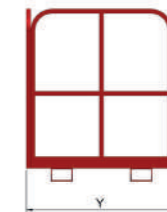
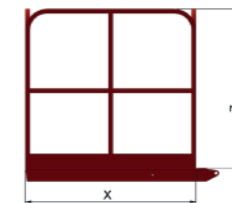

	MODELLNUMMER	WPA
X	BREITE	1200 MM
Y	LÄNGE	1060 MM
Z	HÖHE	1120 MM
M	EIGENGEWICHT	130 KG

TELESKOPLADER

TELESKOPLADER

www.torkongroup.com

SEITE **20-33**

TORKON[®]

Attachments

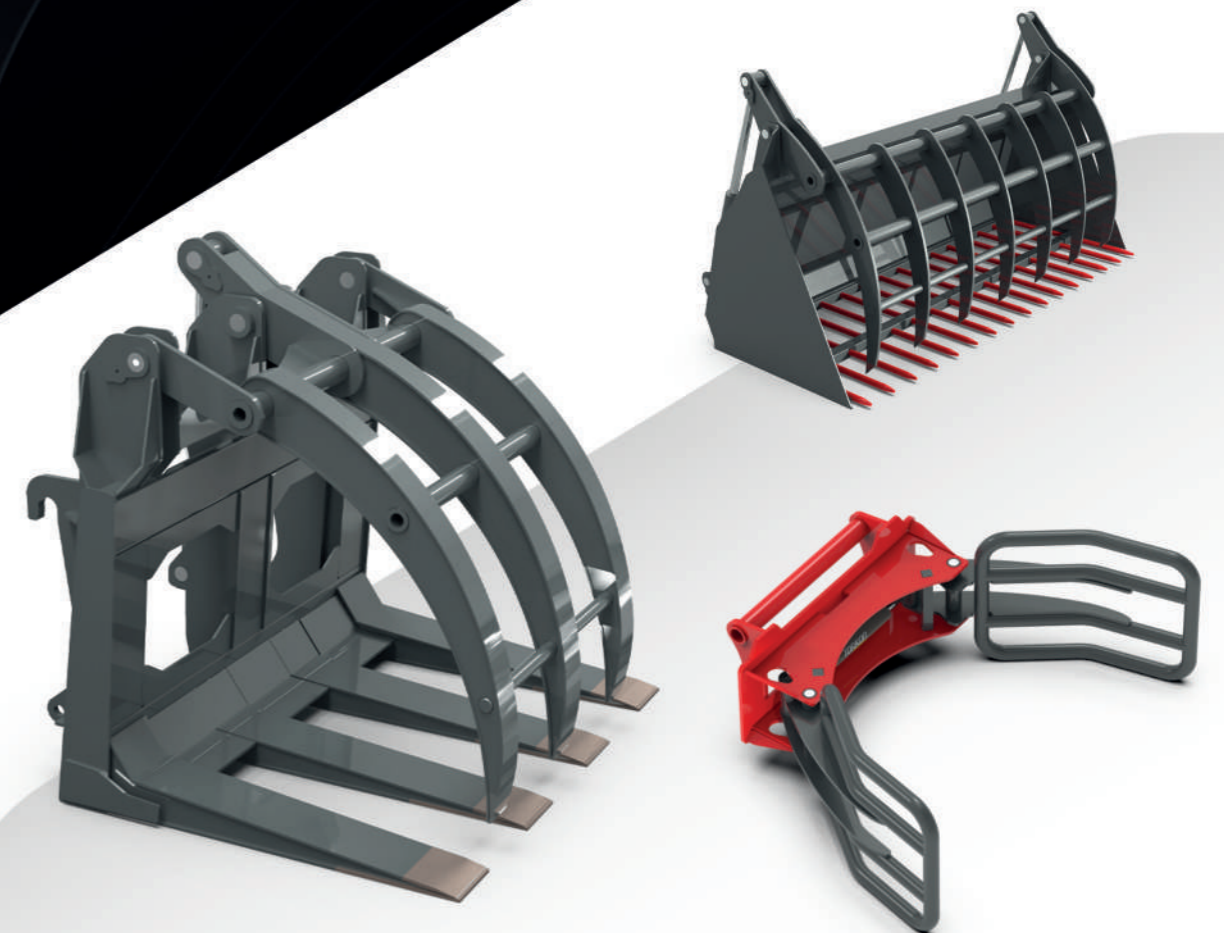



GREIFSCHAUFEL



20



PRODUKTINFORMATION

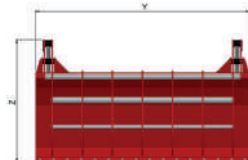
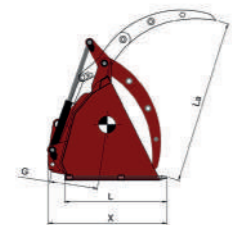

MODELLNUMMER	CCB
V INHALT	1,5 M ³
X/Y/Z GESAMTMASSE B/L/H	1104/2312/1325 MM
L TIEFE	950 MM
LA MAX. GREIFDURCHMESSER	1530 MM
G EIGENSCHWERPUNKT	450 MM
M EIGENGEWICHT (KG)	570 KG
MA TRAGFÄHIGKEIT (KG)	1000 KG

KLAPPSCHAUFEL



21



PRODUKTINFORMATION

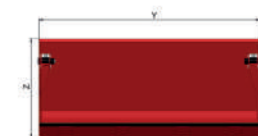
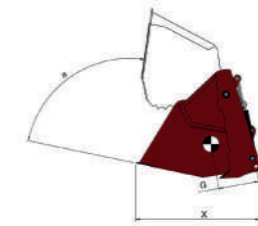

MODELLNUMMER	HOB
X/Y/Z GESAMTMASSE B/L/H	1220/2370/1075 MM
A ÖFFNUNGSWINKEL	83°
G EIGENSCHWERPUNKT	395 MM
H INHALT (M³)	1,35
M EIGENGEWICHT (KG)	715 KG



HYDRAULISCHER GREIFER FÜR QUADERBALLEN

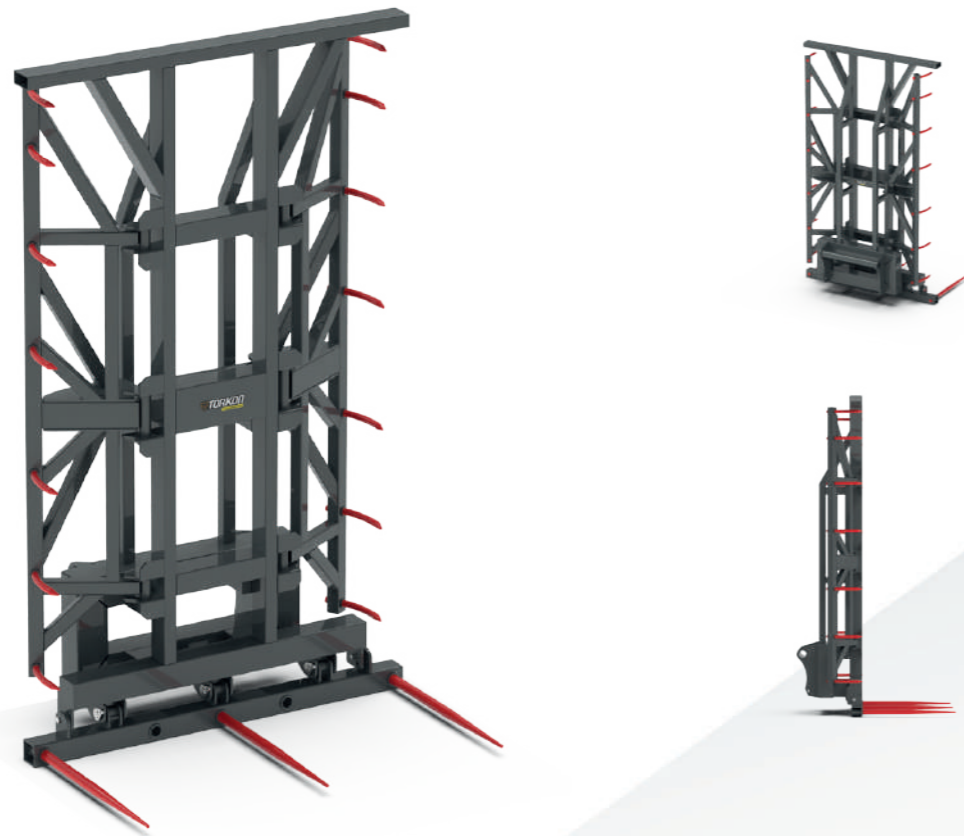

22

PRODUKTINFORMATION

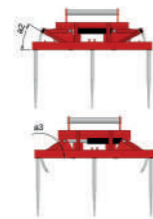
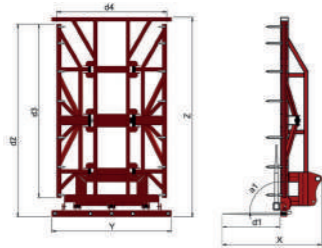

	MODELLNUMMER	HSBA
X/Y/Z	GESAMTMASSE B/L/H	1500/1800/3000 MM
D1	ZINKENLÄNGE	870 MM
D2	TRANSPORTHÖHE	2915 MM
D3	GREIFLÄNGE DER ZINKEN	2625 MM
D4	GREIFBREITE	1650 MM
A1	AKTIVER-PASSIVER ZINKENWINKEL	90°
A2	PASSIVER GREIFZINKENWINKEL	30°
A3	AKTIVER GREIFZINKENWINKEL	30°
M	EIGENGEWICHT (KG)	705 KG
MA	TRAGFÄHIGKEIT (KG)	2000 KG

RUNDE SCHAUFEL FÜR GETREIDE

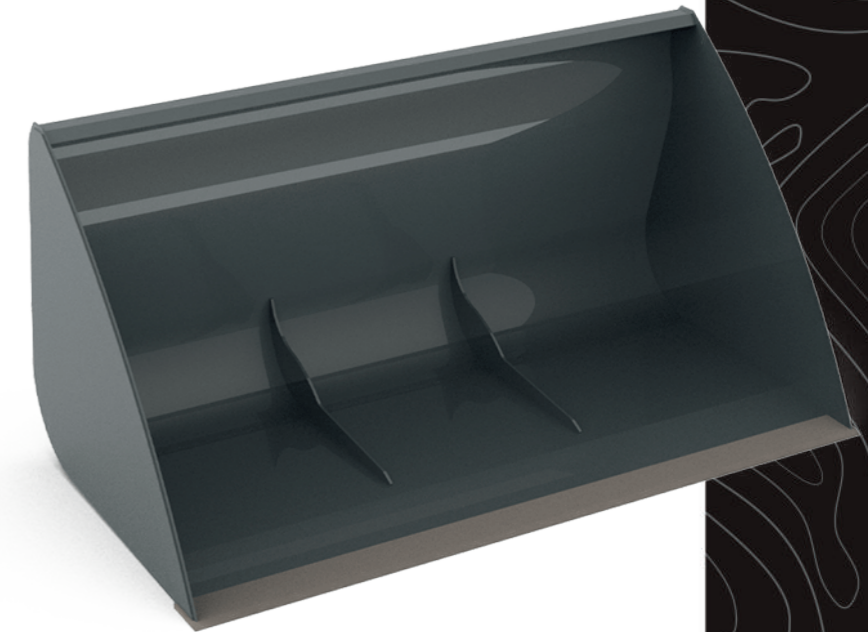

23

PRODUKTINFORMATION



	MODELLNUMMER	LTB-200	LTB-250
V	INHALT	2 M ³	2,5 M ³
X/Y/Z	GESAMTMASSE B/L/H	1450/2400/1200 MM	1765/2400/1395 MM
G	EIGENSCHWERPUNKT	530 MM	570 MM
M	EIGENGEWICHT (KG)	465 KG	540 KG
MA	TRAGFÄHIGKEIT (KG)	1800 KG	2100 KG

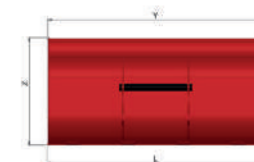
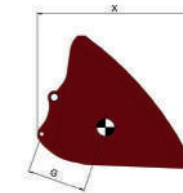



MINI-KLAPPSCHAUFEL

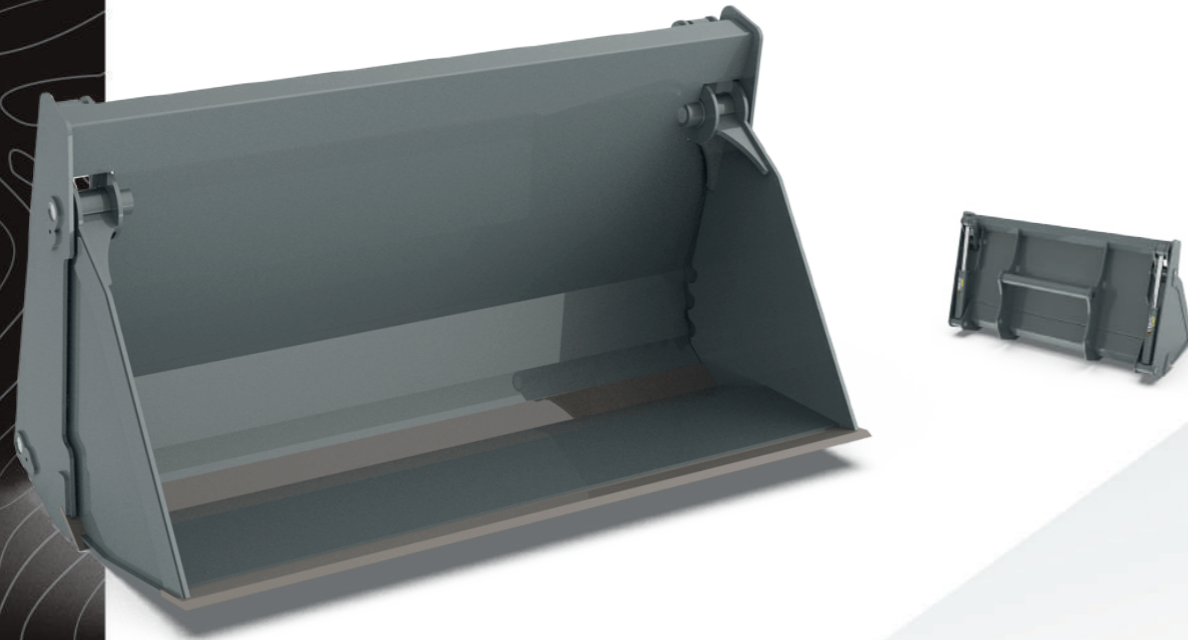

24



PRODUKTINFORMATION

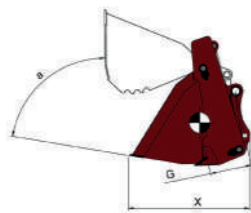

MODELLNUMMER	MOB-150	
X/Y/Z	GESAMTMABE B/L/H	945/1500/1006 MM
A	ÖFFNUNGSWINKEL	80°
G	EIGENSCHWERPUNKT	322 MM
H	INHALT (M³)	0,70
M	EIGENGEWICHT (KG)	465 KG

BALLENZANGE FÜR RUNDBALLEN

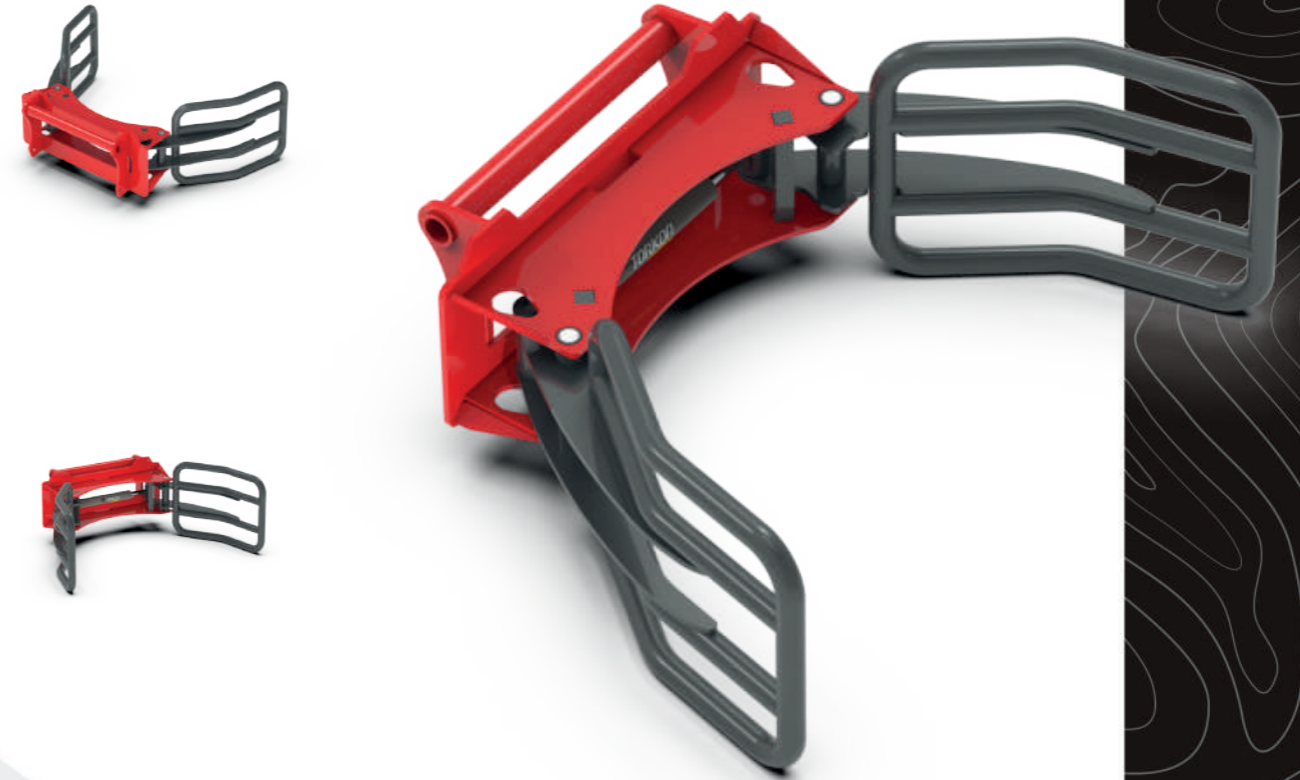

25



PRODUKTINFORMATION

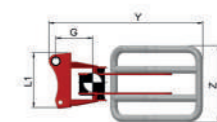
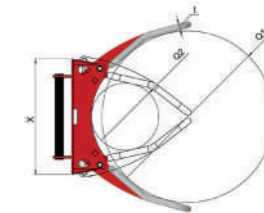

MODELLNUMMER	RBC	
X/Y/Z	GESAMTMABE B/L/H	1100/1310/650 MM
L1	KÖRPERHÖHE	465 MM
Z	ARMBREITE	650 MM
T	ROHRDURCHMESSER	60 MM
Q1	MAX. GREIFDURCHMESSER	1630 MM
Q2	MIN. GREIFDURCHMESSER	640 MM
M	EIGENGEWICHT (KG)	230 KG
MA	TRAGFÄHIGKEIT (KG)	1500 KG
G	EIGENSCHWERPUNKT	315 MM



SCHAUFEL FÜR RÜBEN



26



PRODUKTINFORMATION

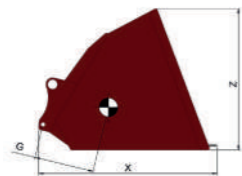

MODELLNUMMER	SBB-200
V INHALT	2 M ³
X/Y/Z GESAMTMAßE B/L/H	1535/2365/1210 MM
G EIGENSCHWERPUNKT	515 MM
M EIGENGEWICHT (KG)	595 KG
MA TRAGKRAFT (KG)	-

PLANIERSCHILD

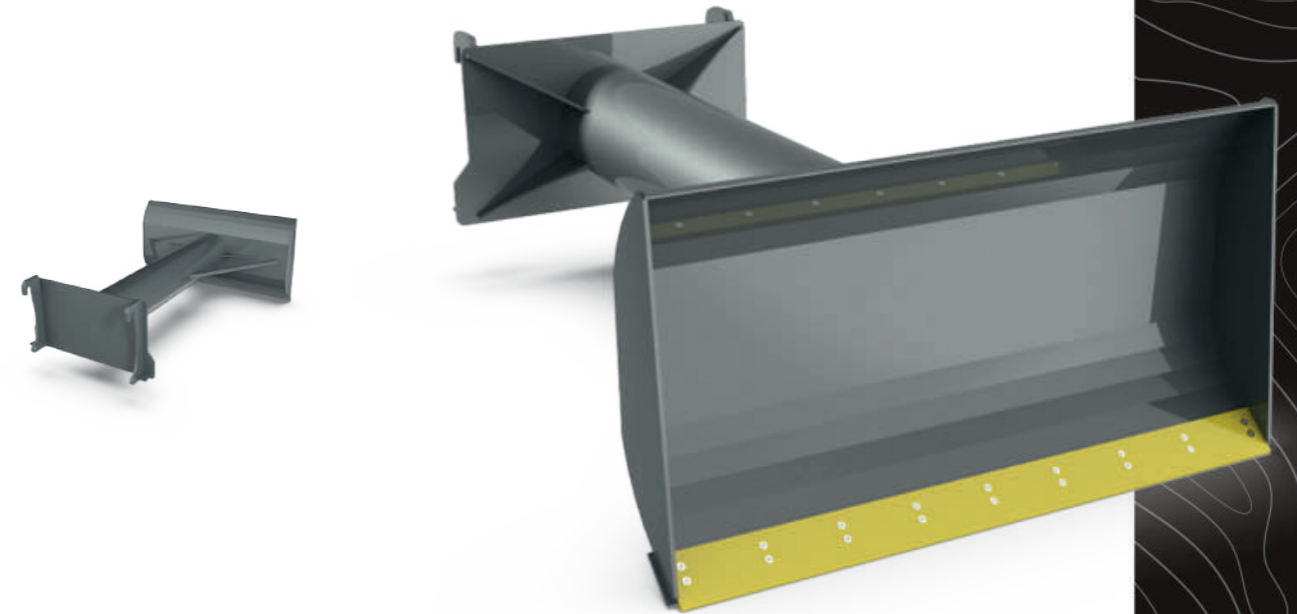

27



PRODUKTINFORMATION



MODELLNUMMER	SLS
X BREITE	3060 MM
Y LÄNGE	2020 MM
Z HÖHE	1100 MM
L ROHRLÄNGE	2500 MM
G EIGENSCHWERPUNKT	1550 MM
M TRAGKRAFT (KG)	515 KG



3-ARMIGER GREIFER FÜR ALTPAPIER



28



PRODUKTINFORMATION

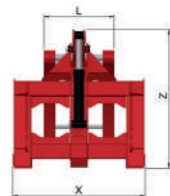
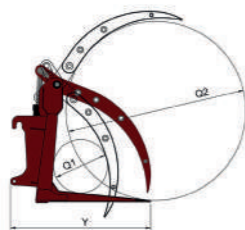

	MODELLNUMMER	SPA-3
Q1	MIN. DURCHMESSER	565 MM
Q2	MAX. DURCHMESSER	1885 MM
X/Y/Z	GESAMTMAßE B/L/H	1390/1470/1450 MM
L	LÄNGE ZWISCHEN 2 GABELN	740 MM
M	EIGENGEWICHT (KG)	600 KG
MA	TRAGFÄHIGKEIT (KG)	-

4-ARMIGER GREIFER FÜR ALTPAPIER

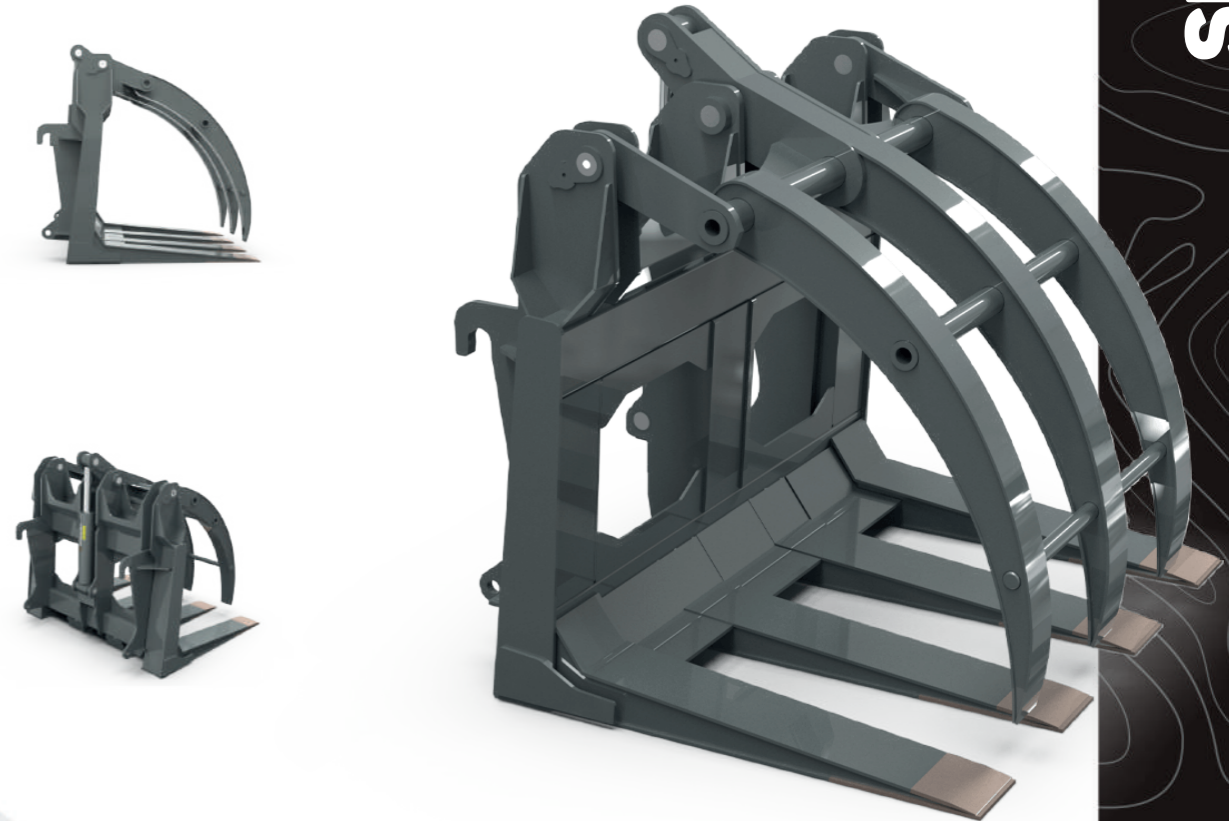

29



PRODUKTINFORMATION

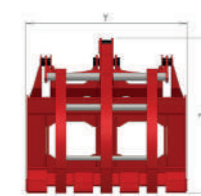
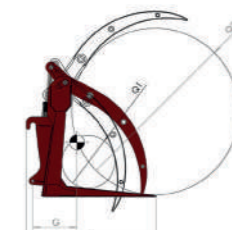

	MODELLNUMMER	SPA-4
X	BREITE	1400 MM
Y	LÄNGE	1520 MM
Z	HÖHE	1460 MM
L	BREITE BEWEGLICHER ARM	960 MM
Q1	MIN. DURCHMESSER	570 MM
Q2	MAX. DURCHMESSER	1800 MM
G	EIGENSCHWERPUNKT	475 MM
M	EIGENGEWICHT (KG)	760 KG
MA	TRAGKRAFT (KG)	2300 KG



GREIFER FÜR QUADERBALLEN

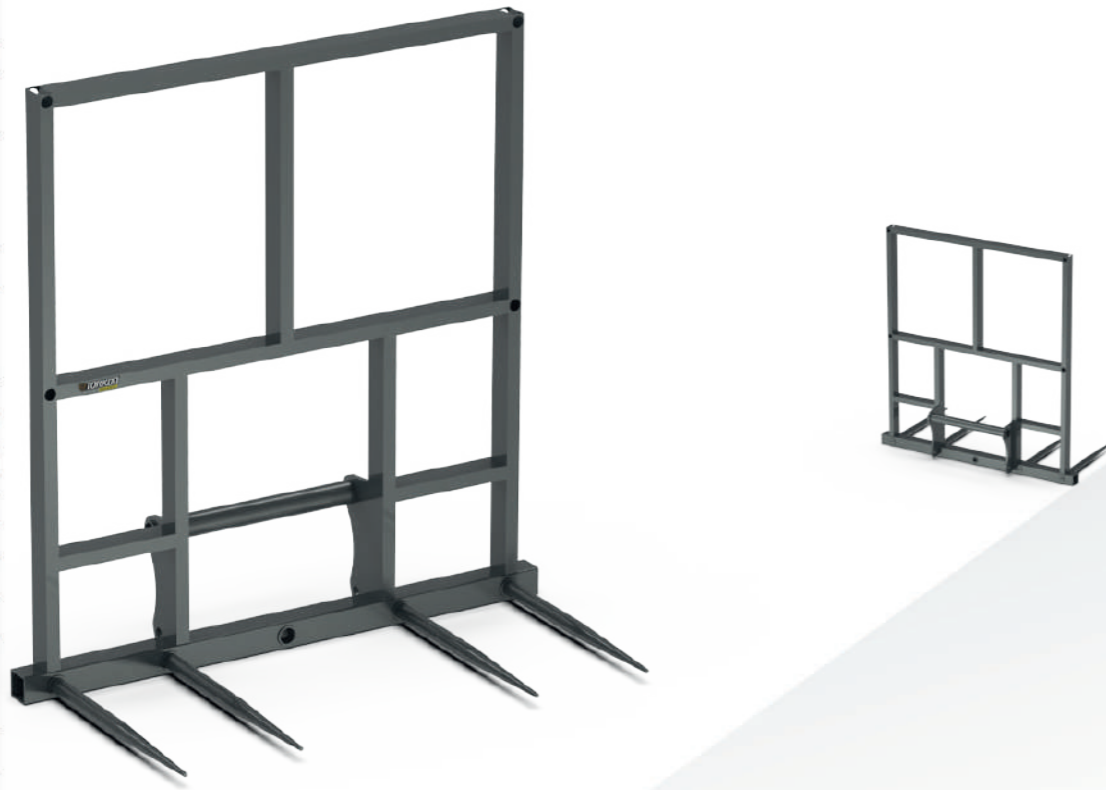

30



PRODUKTINFORMATION

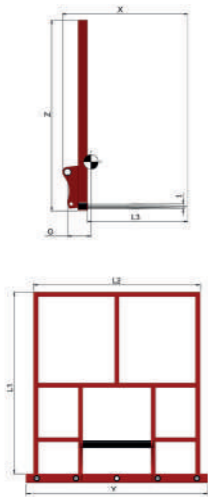

	MODELLNUMMER	SSBA
X	BREITE	1380 MM
Y	LÄNGE	1750 MM
Z	HÖHE	2100 MM
L	ZINKENLÄNGE	1X980 / 2X1210 MM
G	EIGENSCHWERPUNKT	230 MM
M	EIGENGEWICHT (KG)	210 KG
MA	TRAGKRAFT (KG)	2000 KG

HOLZGREIFER

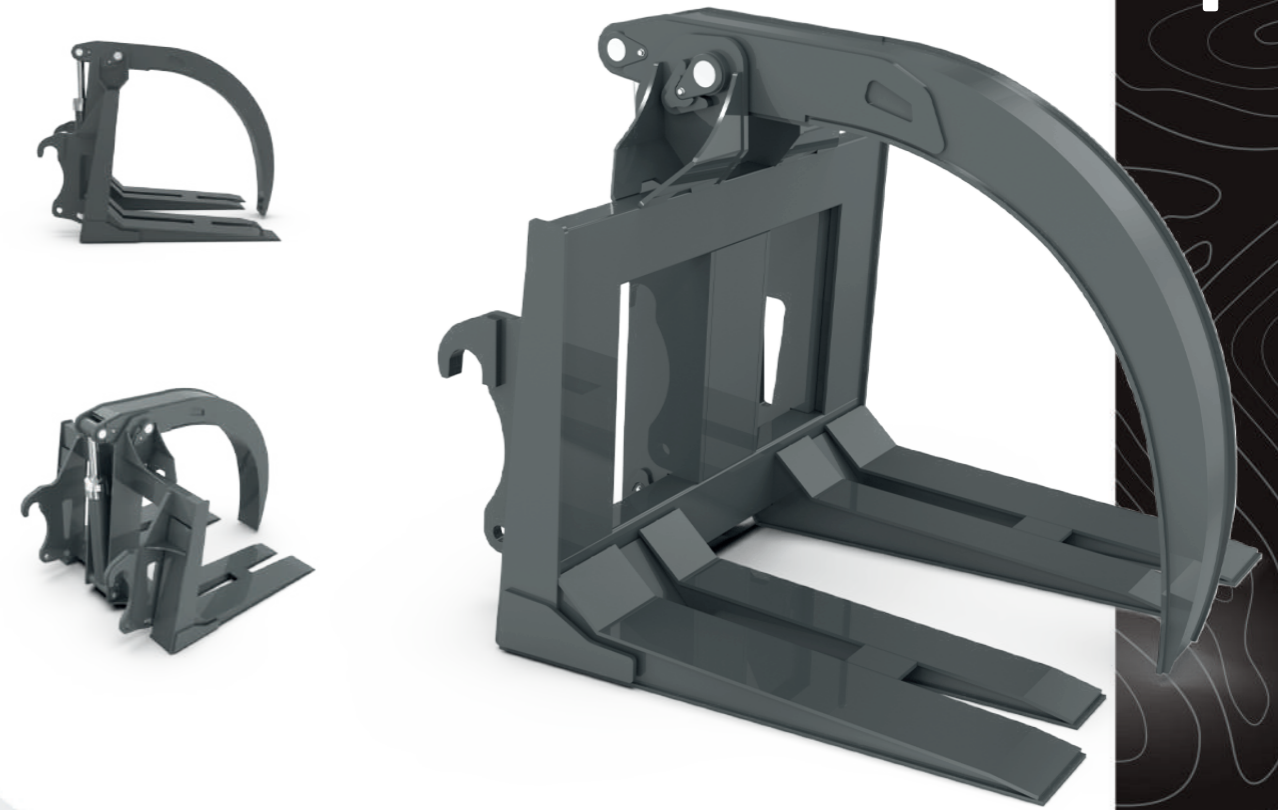

31



PRODUKTINFORMATION

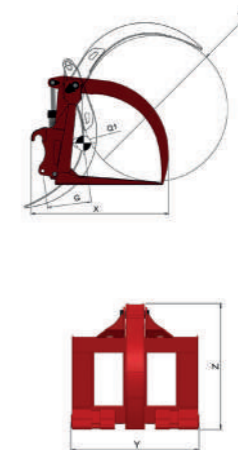

	MODELLNUMMER	TGA
X/Y/Z	GESAMTMASSE B/L/H	1480/1190/1170 MM
Q1	MIN. GREIFDURCHMESSER	103 MM
Q2	MAX. GREIFDURCHMESSER	1565 MM
M	EIGENGEWICHT (KG)	510 KG
MA	TRAGFÄHIGKEIT (KG)	1500 KG
G	EIGENSCHWERPUNKT	473 MM



WAGEN MIT SCHWIMMENDER RÜCKENLEHNE UND GABELN



32

PRODUKTINFORMATION

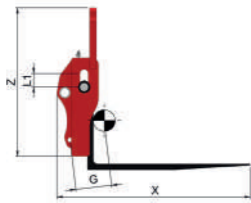

MODELLNUMMER	THFA
X/Y/Z GESAMTMAßE B/L/H	1425/1120/1100 MM
L1 ENTFERNUNG DER BEWEGUNG	100 MM
L2 GABELBREITE	130 MM
G EIGENSCHWERPUNKT	265 MM
M EIGENGEWICHT (KG)	320 KG
MA TRAGFÄHIGKEIT (KG)	-

SCHAUFEL FÜR SAND

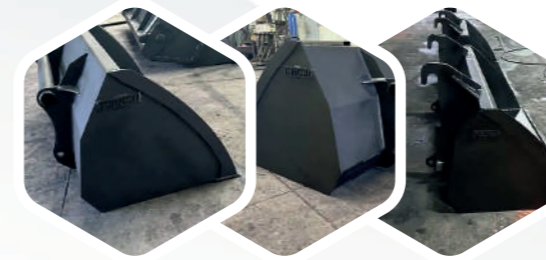
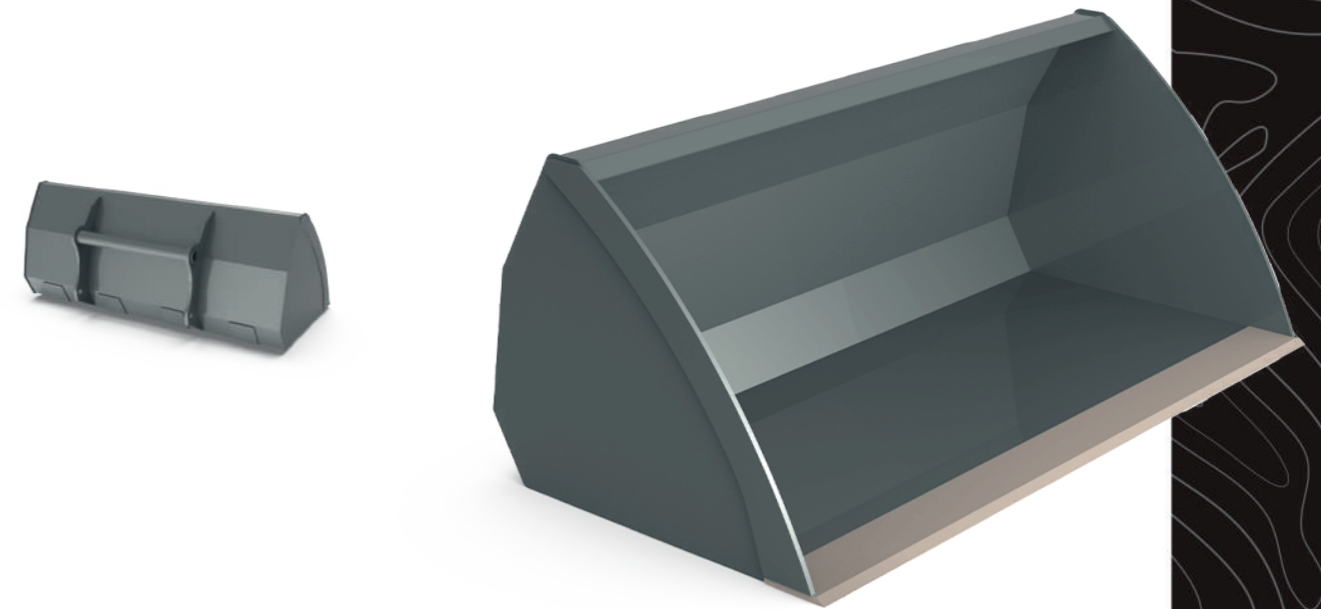

33

PRODUKTINFORMATION

MODELLNUMMER	TSB
X BREITE	1020 MM
Y LÄNGE	1800 MM
Z HÖHE	740 MM
G EIGENSCHWERPUNKT	380 MM
M EIGENGEWICHT (KG)	270 KG
MA TRAGFÄHIGKEIT (KG)	-

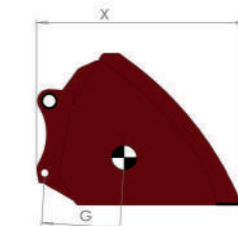

LADER

www.torkongroup.com

SEITE **36-38**

TORKON[®]

Attachments





HYDRAULISCHES PLANIERSCHILD

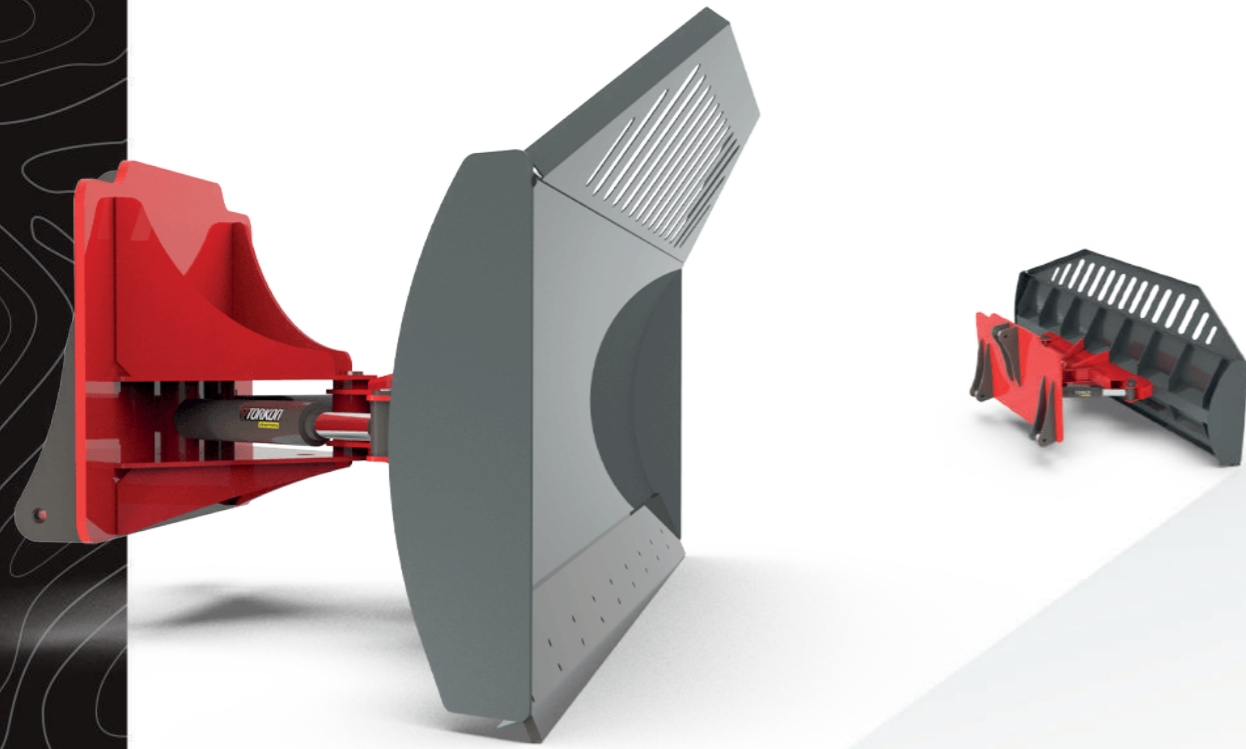

36



PRODUKTINFORMATION

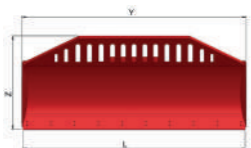
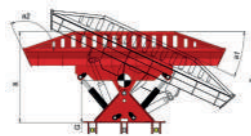

MODELLNUMMER	HLS	
X/Y/Z	GESAMTMAßE B/L/H	1225/2730/1140 MM
L	LÄNGE	2700 MM
A1	DREHWINKEL (RECHTS-LINKS)	25° (25 SAĞ 25 SOL)
A2	KEGELWINKEL	115°
G	EIGENSCHWERPUNKT	565 MM
M	EIGENGEWICHT (KG)	575 KG

HOCHKIPPSCHAUFEL FÜR GETREIDE 2M³

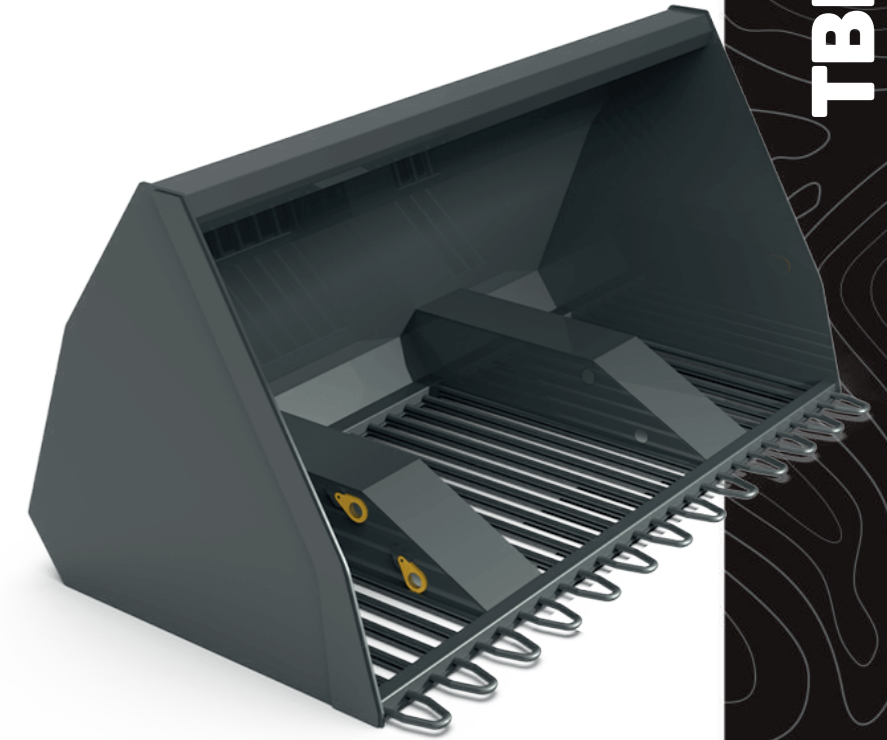
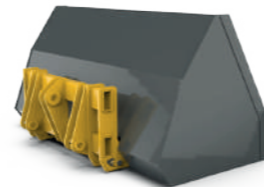

37



PRODUKTINFORMATION

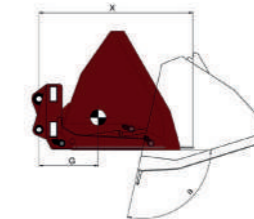

MODELLNUMMER	TBB-200	
V	INHALT	2 M ³
X/Y/Z	GESAMTMAßE B/L/H	1560/2370/1210 MM
A	ENTLADEWINKEL	102°
G	EIGENSCHWERPUNKT	600 MM
M	EIGENGEWICHT (KG)	1000 KG
MA	TRAGFÄHIGKEIT (KG)	1800 KG



HOCHKIPPSCHAUFEL FÜR GETREIDE

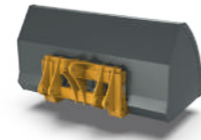
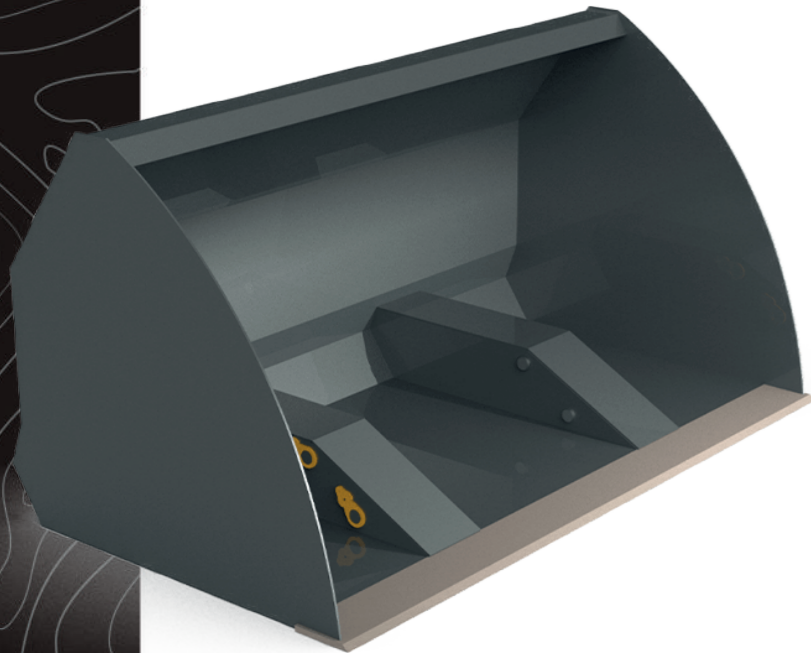

38

PRODUKTINFORMATION

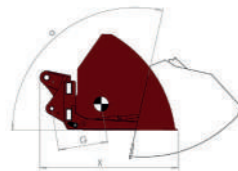

MODELLNUMMER	TWB-300	TWB-200
V INHALT	3M ³	2M ³
X/Y/Z GESAMTMAßE B/L/H	1865/2500/1300 MM	1540/2400/1200 MM
A ENTLADEWINKEL	103°	102°
G EIGENSCHWERPUNKT	670 MM	605 MM
M EIGENGEWICHT (KG)	1250 KG	1125 KG
MA TRAGFÄHIGKEIT (KG)	3000 KG	3000 KG

MINI LADER

www.torkongroup.com

SEITE **40-41**

TORKON
Attachments

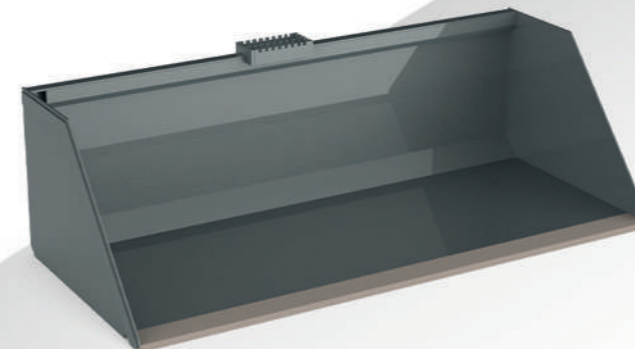



SCHAUFEL

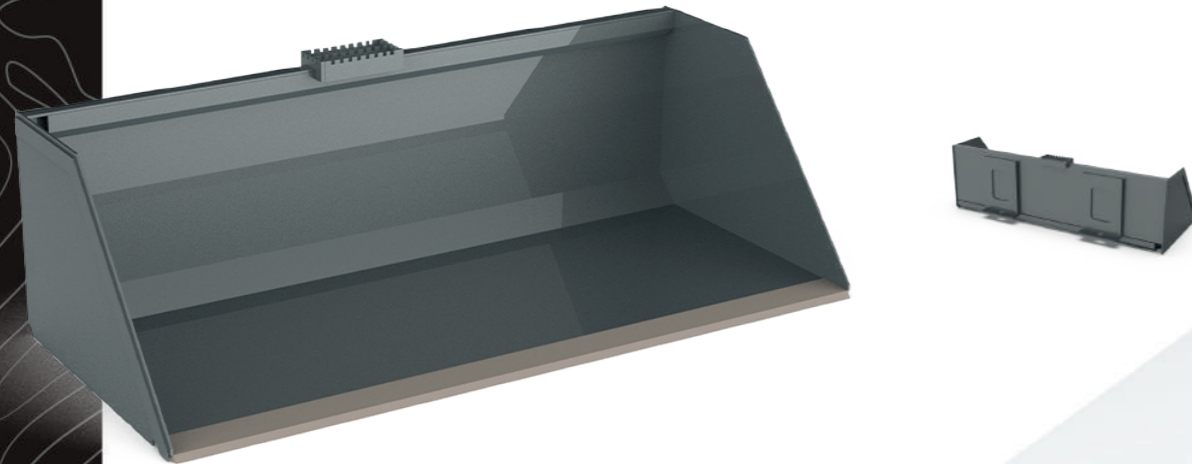

40

PRODUKTINFORMATION

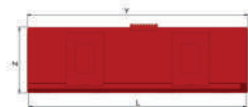
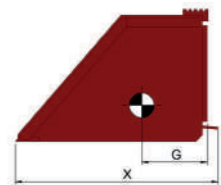

MODELLNUMMER	MLB
X/Y/Z GESAMTMABE B/L/H	845/1774/530 MM
L LÄNGE	1750 MM
G EIGENSCHWERPUNKT	275 MM
M EIGENGEWICHT (KG)	200 KG
MA TRAGFÄHIGKEIT (KG)	1000 KG
V INHALT	0,3M ³

GABELTRÄGER

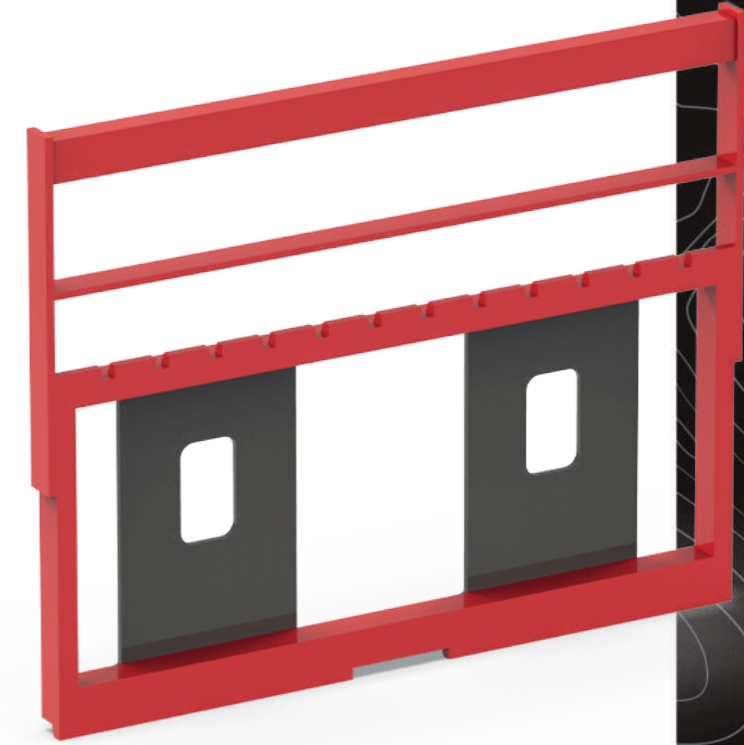

41

PRODUKTINFORMATION

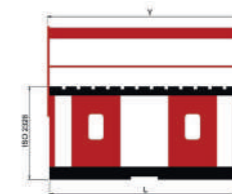

MODELLNUMMER	MLFA-3A
X/Y/Z GESAMTMABE B/L/H	125/1075/850 MM
L KÖRPERLÄNGE	1050 MM
ISO 2328 ISO NORM	3A
G EIGENSCHWERPUNKT	27 MM
M EIGENGEWICHT (KG)	100 KG

ATTACHMENTS
PRODUKTKATALOG

**ENTFESSELN SIE DIE
LEISTUNG.**

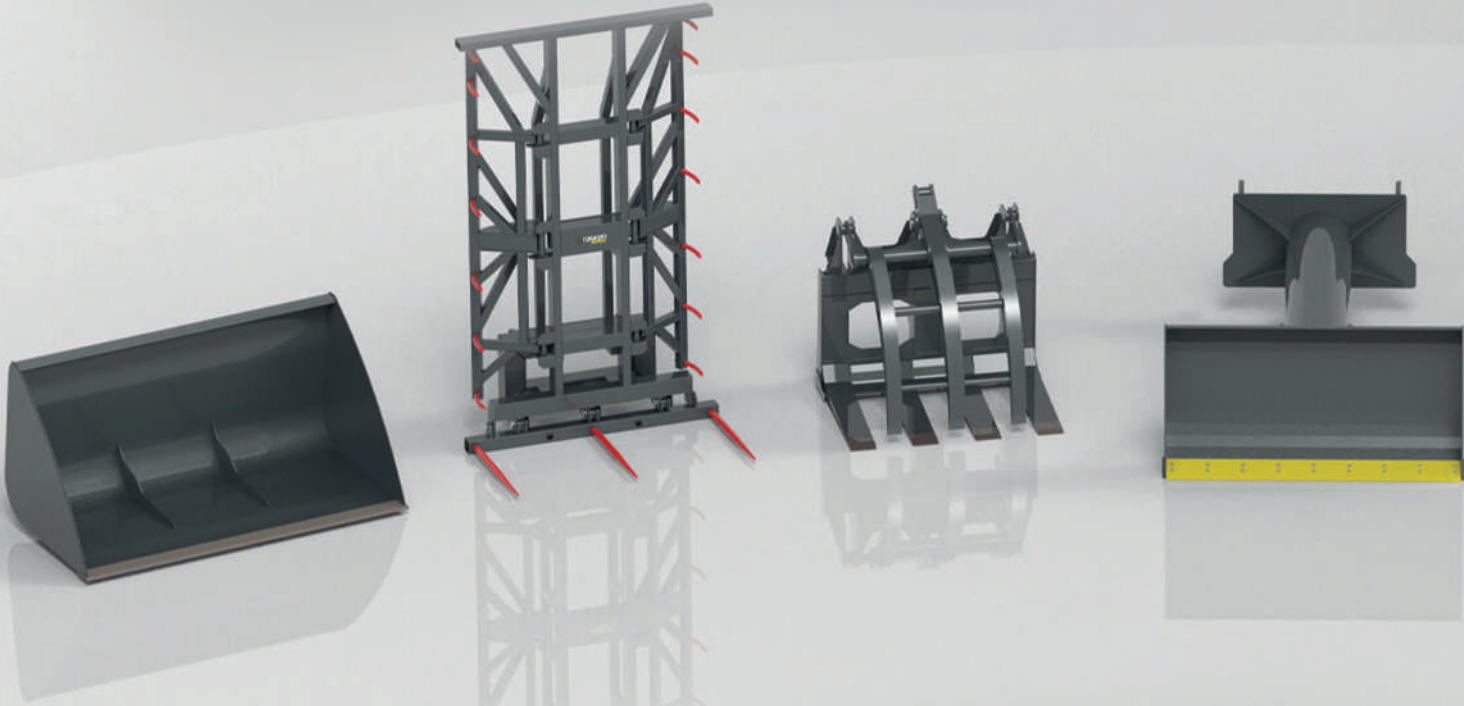

 **TORKON**[®]
Attachments

www.torkongroup.com

+49 172 253 5530
info@torkon.com.tr

HOROZLUHAN, ILKAY SK. NO:14,
42110 SELÇUKLU/KONYA/TÜRKİYE